

BHORUKA

A YKK AP COMPANY

Extruding Excellence



Admired Companies to watch in India 2025 by **Forbes India**

Tomorrow's Mettle

BHORUKA EXTRUSIONS PRIVATE LIMITED

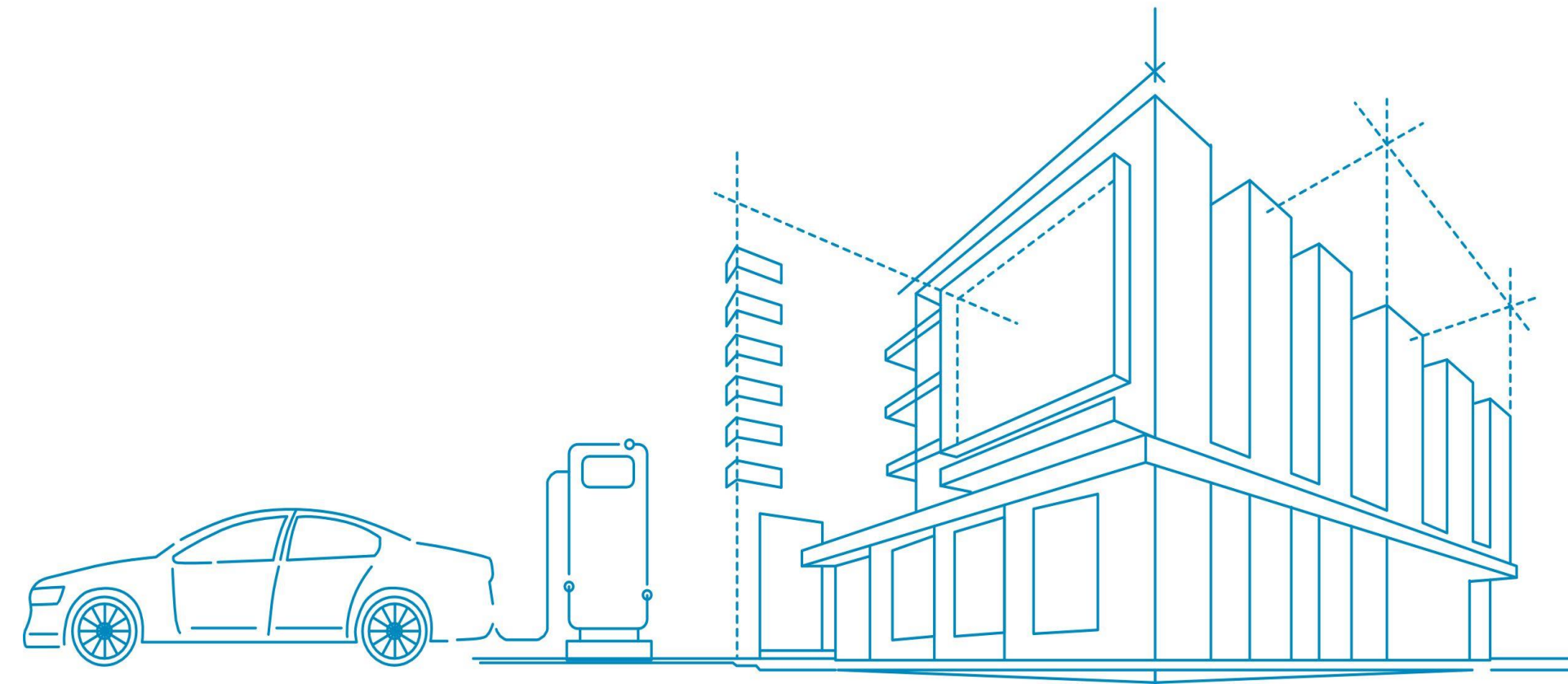

Vision

Our **vision** is to be the **Preferred Extruder** of choice for iconic projects by delivering products and services that reduce our **customers' total cost of ownership**.

We do this by **leveraging technology** and a commitment to sustainability, customer satisfaction, and operational excellence

Path to becoming preferred Extruder



- Customer Satisfaction**
Ensuring Client needs are met with High Quality Service

- Operational Excellence**
Streamlining processes for Optimal Performance

- Leveraging Technology**
Leveraging Technology to enhance efficiency and real Time access.

- Sustainability**
Implementing Eco-friendly practices for long term viability

About Us

Established in 1979

100% subsidiary of
\$6.5 Billion YKK AP Inc.
Japan

Extrusion capacity of
15,500 MT / Annum
(6" / 8" / 9" / 9" - extrusion
press)

In-house Anodizing
capacity of 250 MT /
Month (Italtechno, Italy)

In-house Powder coating
capacity of 400 MT /
Month (Nordson , U.S.)

In-house Machining Facility
with new CNC Machining
Centres from FOM
Industries, Italy

»» Key Highlights

★ SAP Implementation Award



Award winning SAP
implementation
(ECC 6.0) in Metal Sector

★ Online Self-Updating E-catalogue

BHORUKA
A YKK AP COMPANY
e-catalogue

Instant access to thousands of
profiles listed in different
categories

★ Bhoruka 360 CRM & E Planner

BHORUKA 360°
A YKK AP COMPANY
BHORUKA eplanner
A YKK AP COMPANY

Online order tracking through
Bhoruka 360 CRM portal) and
Planning (E-Planner)

★ Approved Extruder for System Windows



Airclos, AluK, Asahi, Dorma
IWIN, Schueco & others



About YKK AP

Philosophy



CYCLE OF GOODNESS

“No one prospers without rendering benefit to others”

If we keep creating **new values by innovative ideas and inventions** through our business activity, we can expand our business. That brings **prosperity to our customers** and business partners, and as a result, we can **make a contribution to society**



Tadao Yoshida
Founder of YKK

YKK Group Structure

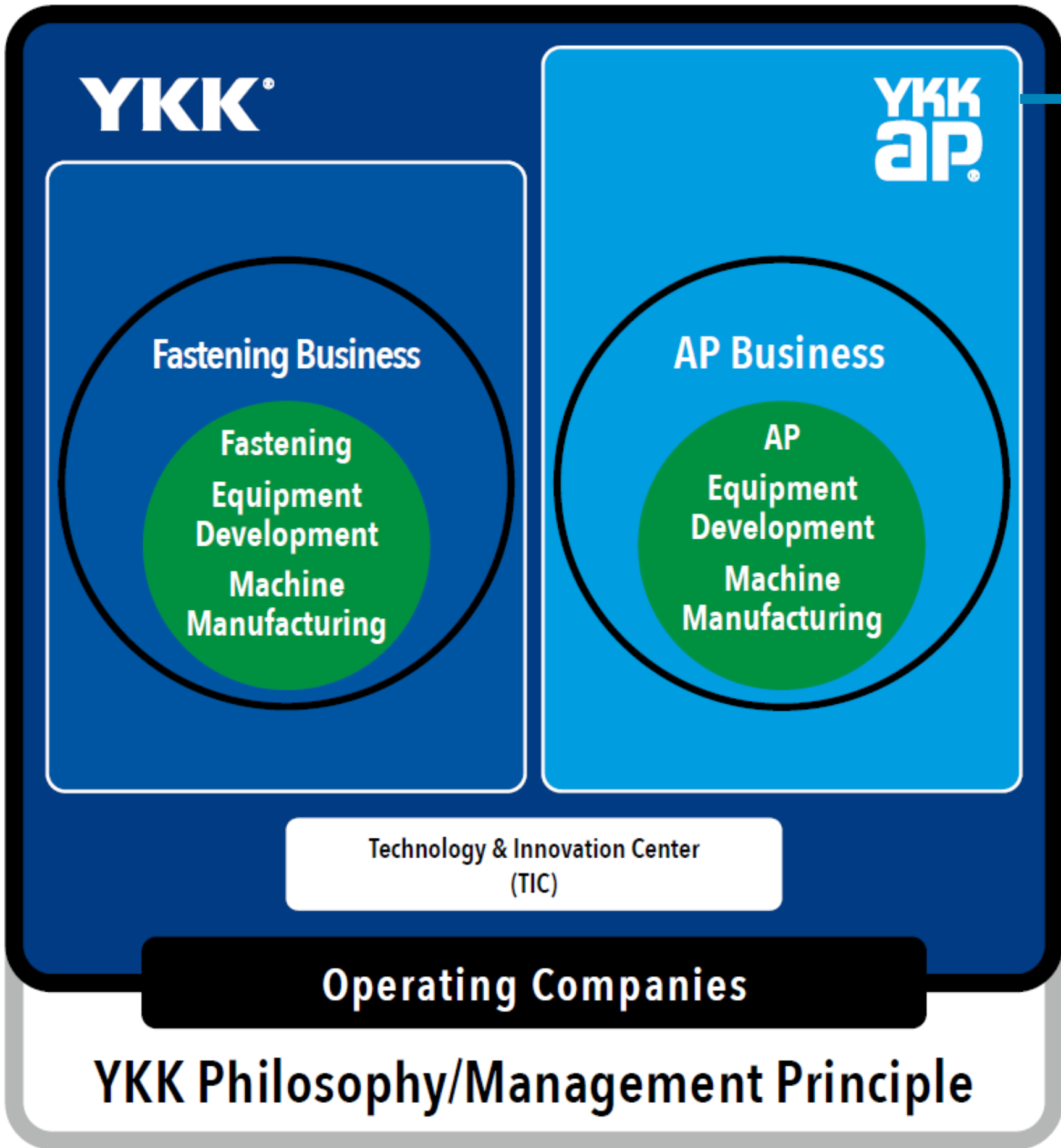

BHORUKA
A YKK AP COMPANY



Profile Business

100% made-to-order aluminium extrusion that caters primarily to the building & construction sector & OEM Sector



System Business

IWIN Aluminium Doors and Windows is a home-creation B2B brand designed by YKK AP with Japanese Precision.

About YKK AP

YKK AP was incorporated as a subsidiary of a zipper manufacturing company in 1957. Since entering the architectural products business, it has grown worldwide to become a leading company in its field

Category	Details	FY 2024-25
Number of Employees	Japan	13,337
	Ratio of Men to Women (Japan)	Men: 73% / Women: 27%
	Overseas	4,915
Women in Management	Number of Employees	148
	Ratio	6.80%
Employment of Persons with Disabilities	Average Rate	2.44%
Climate Change Indicators	Scope 1 & 2 Emissions	271 ktCO ₂ (-37%)
	Scope 3 Emissions	2021 ktCO ₂ (-19%)
Number of Locations	Japan	194
	Overseas	58
Manufacturing Sites	Japan	24
	Overseas	12

Purpose of YKK AP

*We Build a Better Society
Through Architectural Products*

With a spirit of curiosity and exploration, we develop architectural products of true value that connect people, planet, and the future.

We want to create a better society, while remaining committed to the art and technology that have always been fundamental to architectural culture

Sales	FY2024-25
Net sales (consolidated)	\$3.74 billion
Japan	\$3.13 billion
Overseas	\$0.83 billion
Overseas ratio	18%

1USD=142.92JPY

Global Presence

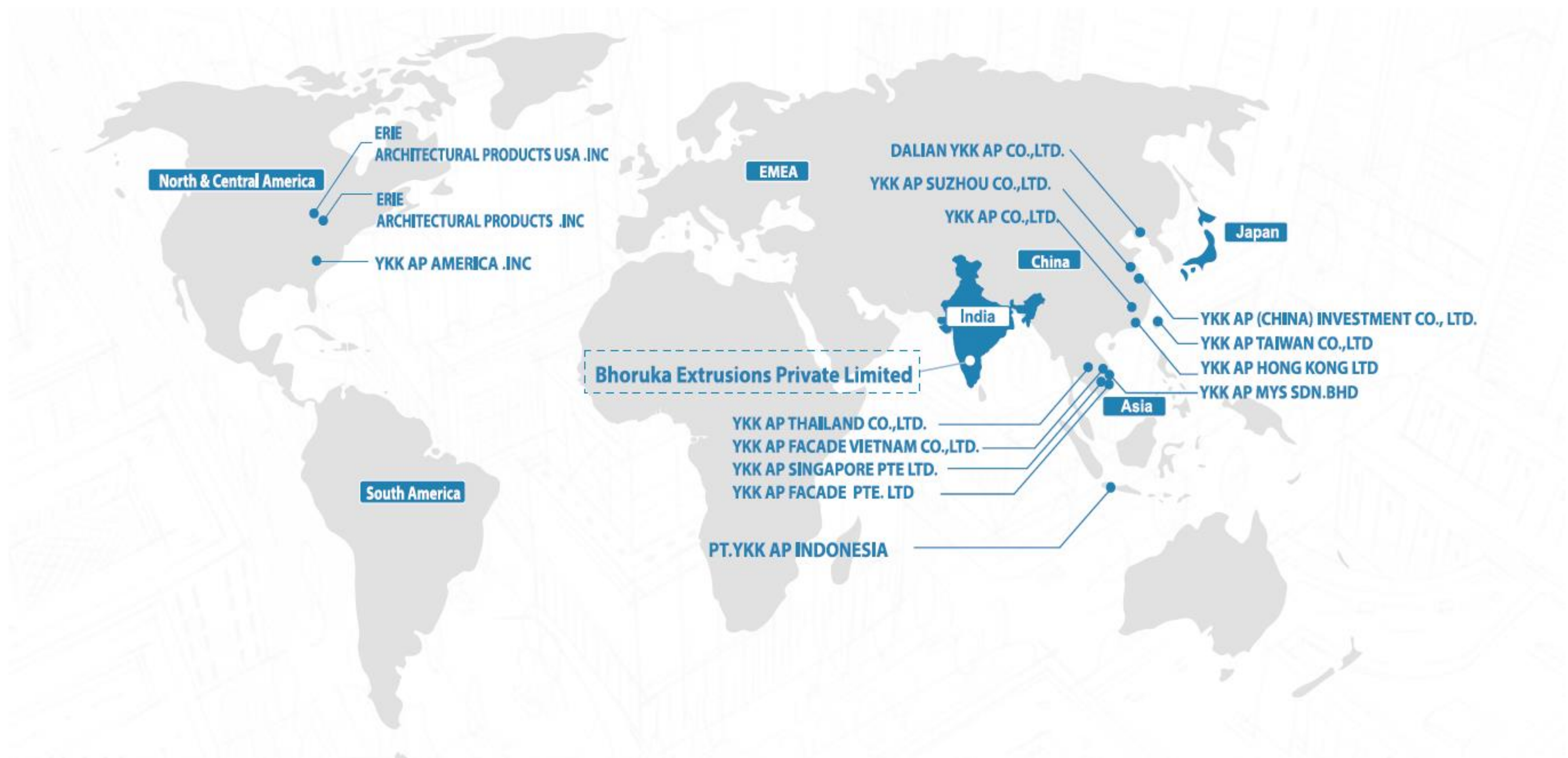

North & Central America

ERIE ARCHITECTURAL PRODUCTS USA .INC

ERIE ARCHITECTURAL PRODUCTS .INC

YKK AP AMERICA .INC

South America

EMEA

Bhoruka Extrusions Private Limited

India

China

DALIAN YKK AP CO.,LTD.

YKK AP SUZHOU CO.,LTD.

YKK AP CO.,LTD.

Japan

YKK AP (CHINA) INVESTMENT CO., LTD.

YKK AP TAIWAN CO.,LTD

YKK AP HONG KONG LTD

YKK AP MYS SDN.BHD

Asia

YKK AP THAILAND CO.,LTD.

YKK AP FACADE VIETNAM CO.,LTD.





YKK AP SINGAPORE PTE LTD.

YKK AP FACADE PTE. LTD

PT.YKK AP INDONESIA

Why Bhoruka ?

Bhoruka Extrusions is a **45 year old** trusted brand in Aluminum Extrusion Industry which is owned & guided by YKK AP Inc., Japan - the largest player in the global façade & fenestration business. Our customers are our most valuable partners. We believe in a customer-centric approach where understanding and addressing customer need is our top priority. We will listen, adapt, and deliver solutions that precisely meet customer requirement.

- **Technology-enabled value creation**
Bhoruka 360 and E-planner offer customers real-time order tracking, estimated dispatch dates and document access.
- **Compliance & certifications**
Bhoruka ensures full compliance with global standards through certifications like ISO, BIS, IGBC, GRIHA REACH & ROHS
- **Ensuring high level of reliable OTIF**
Using E Planner and streamlined processes to consistently achieve high On-Time In-Full (OTIF) reliability.
- **Optimum Cost of ownership**
Mean weight billing, dispatch tolerance, and matching section ensure optimal ownership cost for the customer
- **Integrated Manufacturing Facility**
Integrated Extrusion facility with Toolroom, Anodizing, Powder Coating and machining Unit.

Our Long-term Strategic Framework

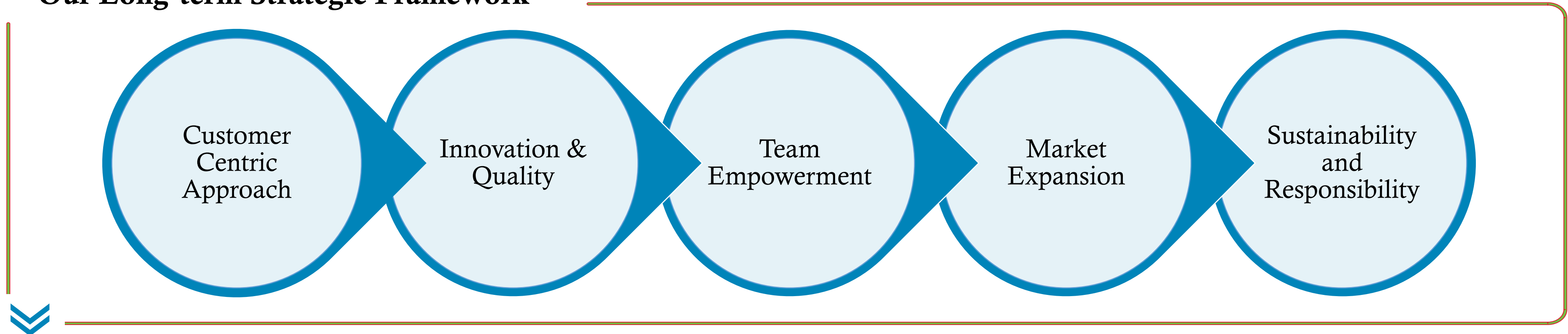

Key Differentiators

Factor	Bhoruka Extrusions	Competitor	Advantage at <u>Bhoruka Extrusions</u>
SO Release	In Pieces	In Kgs	Matches with the Cutting List of Fabricator or Façade Contractor Software
Weight Measurement	Drawing Mean Weight	Actual Weight	Matches with Tender weight, PO-Invoice consistency, ~3.5% savings on powder weight
Dispatch Tolerance	1-1000 pcs (-0%+5%)/ >1000 pcs (-0%+2%)	+/- 10% in Kgs	Reduced inventory and less total cost
Matching Section	Ageing and Invoice Blocked	No Check.	Reduced inventory at Customers
Order Status	Online through Bhoruka 360 CRM Portal	NA	Customer can track PI-PO-SO-Production-Dispatch online
Estimated Dispatch Date	Through E-Planner in Bhoruka 360 CRM Portal	Excel	Customers can plan operations based on estimated date of dispatch

Key Differentiators

How Bhoruka's planning team optimizes material flow, order & OTIF fulfillment?

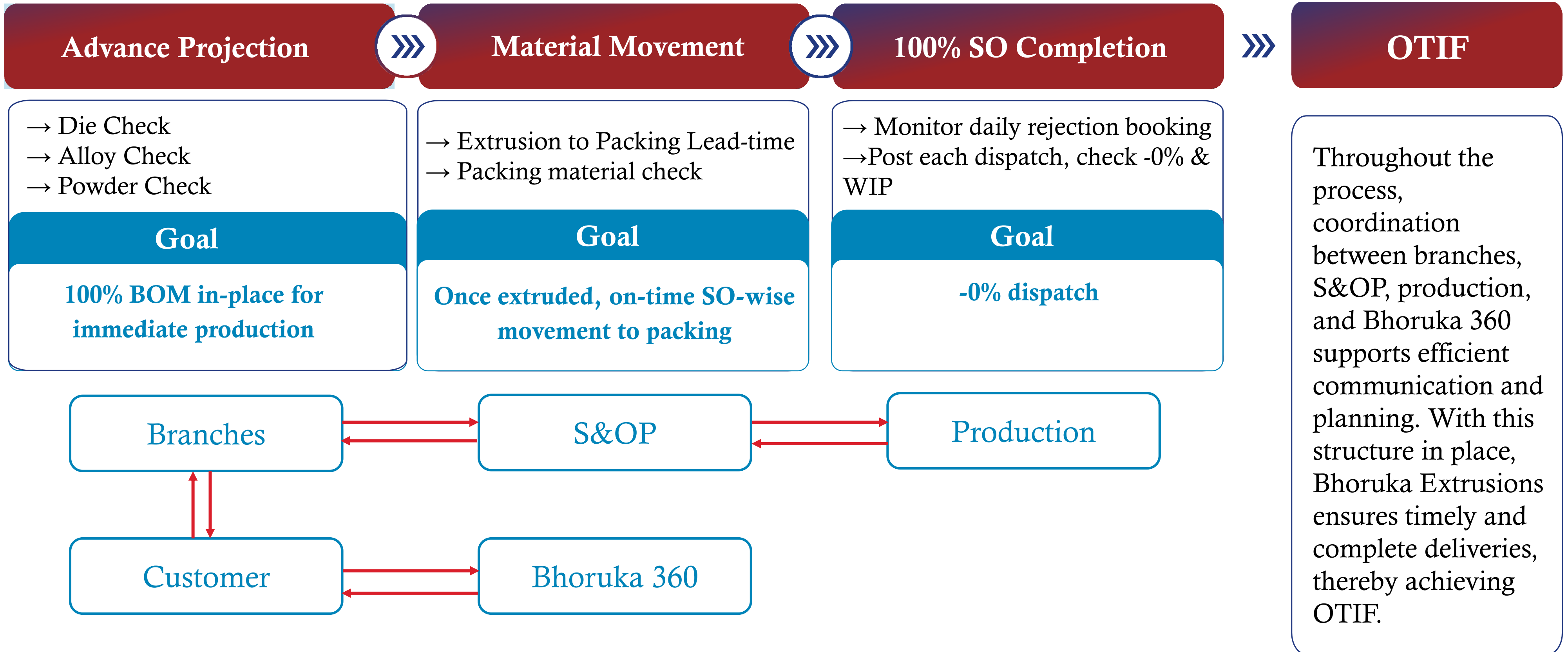

On Time: Delivering the aluminum extruded profiles to the customer exactly by the agreed date.

In Full: Supplying the complete quantity and specifications of extruded profiles as ordered, without any shortages or errors.

Key Differentiators

How Bhoruka's planning team monitor production to Dispatch Process Flow?

With powerful tools like the **Advance Planning** and **EDD Trackers**, we ensure every Sale Order moves like **clockwork** from SO Release to delivery. At Bhoruka, production to dispatch isn't just managed, it's mastered with proactive planning, real-time monitoring, and seamless coordination

Projection- SO Release

Alloy, Die & Powder

- ☞ 3 Months Forecast
- ☞ Monthly Plan
- ☞ Monthly Estimation
- ☞ Weekly Estimation
- ☞ PO & Approved PI
- ☞ SO Release
(Bhoruka 360 + E Planner)



SO Release - Dispatch

Planning, Material Movement & Dispatch

- ☞ Planning (Priority Rule)
- ☞ Monthly Dispatch Tracker
- ☞ Production
- ☞ Rejection Planning if any
- ☞ Packing
- ☞ Dispatch Planning
- ☞ Post Dispatch Activities

MONITORING PROCESS	METHODOLOGY
Monitoring ADP status, from projection to SO Release	Advance Planning Google Sheet
Daily Planning & Completion monitoring	Weekly planning and Online DPH
Movement of material at all storage locations	Inventory Tracking Google Sheet
All quality rejections are re-planned within 24 hours	Rejection Recreation Google Sheet
EDD committed Sales Orders	EDD Tracker Google Sheet
100% SO Completion monitoring based on Dispatch Tolerances	Short Close Report

Integrated Facility



State-of-the-art
manufacturing facility in
Mysore, Karnataka



New Development - New
Extrusion Press (HLT)
commissioned in
Sep 2025



ToolRoom

- › Equipped with Conventional and CNC Machining Centres

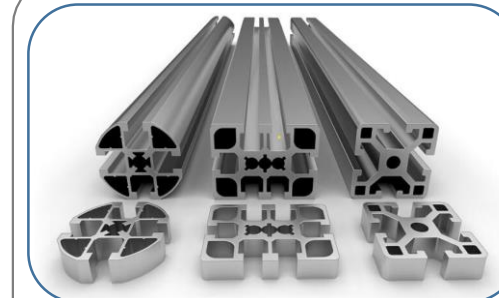

Extrusion

- › Equipped with 6", 8", 9", 9" Extrusion Press with a Capacity of 1550MT/Month



Anodizing

- › 7 Tank Treatment Plant with Black, Silver, Champagne and Bronze Shades



Powder Coating

- › Hexavalent Chromium Process with any any RAL Shades



Machining

- › Machining Centres from FOM Industry Italy



Foundry

- › Oil Fired furnace to cast billets in-house from the in-house rejection

Equipment's

TECHNICAL FACT SHEET				
Parameters	Press-1	Press-2	Press-3	Press 4
MAKE	Wean United (USA)	Year Chang (Taiwan)	Cheng Hua (Taiwan)	HLT (China)
Strength of extrusion press (TONS)	1800	1100	2750	3000
Diameter of billet	203 mm	152 mm	228mm & 203mm	228mm
Maximum pressure of Press (BAR)	210 BAR	210 BAR	230 BAR	305 BAR
Mark of Billets	6063, 6005, 6105, 6061		6063, 6060, 6101, 6005, 6351, 6061, 6082	6060, 6063, 6005, 6061, 6082, 6101 & 6351 (Other 6XXX series based on requirement)
(6063-6060)				
Type of Billet Oven (gas, diesel, induction)	Hot log shear	Induction	Hot log shear	PNG
Type of Puller	Track type	Track type	Track type	Double Fly Saw Puller

New Development - New Extrusion Press (HLT): The commissioning of Press 4 in September 2025 has significantly enhanced extrusion capacity and enabled larger profile sizes.

TOOL ROOM	
Die types	Solid, Hollow, Semi-hollow
Dia CCD	Solid – 300mm; Hollow-280mm
# of sections	>18,000
Lead Time	Solid - 15 days; Hollow - 21 days

BHORUKA ANODISING	
Make	Italteco, Italy
Microns	5 to 25
Colors	Silver, Champagne, Bronze , Black
Maximum Length	6400 mm
Finish	Matt, Brush

BHORUKA POWDER COATING	
Pre - Treatment	Chemetall, Germany
Powder Coating	Nordson , U.S.
Spray System	Automatic
Thickness Range	60 To 120 Microns
Colors	All RAL Shades
Type	Metallic / Non Metallic
Gloss	High Glossy, Semi Glossy, Matt
Finish	Plain, Texture
Max Length	7500 mm

MACHINING	
Machining Centres	FMC 340, Blitz Alva-550 Double Head Cutting
Make	FOM Industries, Italy
Operations	Milling, Drilling, Boring, Countersinking, Angle Cutting, Turning & Tapping

Alloy Details

Chemical Composition as Per EN 573-3:2007

Alloy	Si	Fe	Cu	Mn	Mg	Cr	Zn	Ti	Aluminum Min
6063	0.20-0.60	0.35	0.1	0.1	0.45-0.90	0.1	0.1	0.1	Remainder
6060	0.30-0.60	0.10-0.30	0.1	0.1	0.35-0.60	0.05	0.15	0.1	Remainder
6061	0.4-0.8	0.7	0.15-0.4	0.15	0.8-1.2	0.04-0.35	0.25	0.15	Remainder
6005	0.6-0.90	0.35	0.1	0.1	0.40-0.60	0.1	0.1	0.1	Remainder
6105	0.6-1.0	0.35	0.1	0.15	0.45-0.8	0.1	0.1	0.1	Remainder
6082	0.7-1.3	0.5	0.1	0.4-1.0	0.6-1.2	0.25	0.2	0.1	Remainder
6101	0.30-0.7	0.5	0.1	0.03	0.35-0.8	0.03	0.1	0	Remainder
6351	0.7-1.3	0.5	0.1	0.40-0.8	0.40-0.8	0	0.2	0.2	Remainder

Mechanical properties as per DIN 755-2/IS-1285

Alloy/T6	Tensile Strength, <i>min</i> MPa	Proof Stress <i>min</i> MPa	Elongation A50mm <i>min</i> in %
6060	185	150	7
6101	200	170	8
6063	185	150	7
6005	255	200	15
6105	260	240	8
6061	290	235	7
6351	295	255	7
6082	295	255	7

◆ **T4 Temper**

Solution heat treated & naturally aged

◆ **T5 Temper**

Cooled from hot working and artificially aged (at elevated temperature)

◆ **T6 Temper**

Heat-treated and artificially aged

◆ **T66 Temper**

Heat-treated and artificially aged using a special process to improve mechanical properties

Extrusion Range

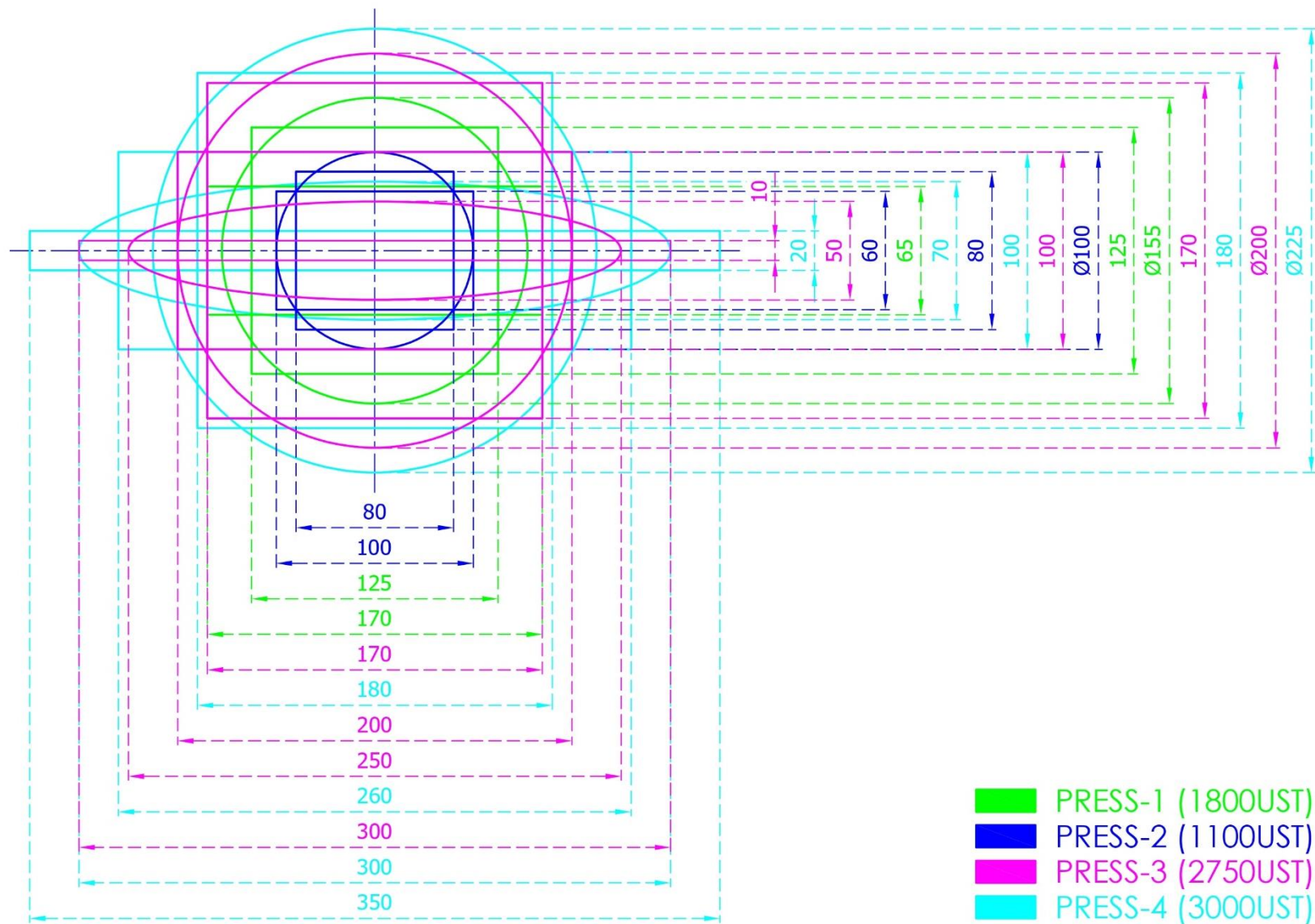

- ◆ Unique Identification mark in all new profile developments (since 2015)
- ◆ It will be located at only non-functional and unexposed/hidden area of the profile.
- ◆ This Identification mark will be prominent throughout the profile length (utilizing only 0.3mm thickness)
- ◆ ID mark will be non-functional/ un-exposed area)

Shape	Press-1 (8"-1800 UST)	Press-2 (6"-1100 UST)	Press-3 (9"-2750 UST)	Press-4 (9"-3000 UST)
Square (A×B)	125 × 125 mm	80 × 80 mm	170 × 170 mm	180 × 180 mm
Rectangle (W×H)	170 × 65 mm	100 × 60 mm	200 × 100 mm	260 × 100 mm
Round (Ø)	Ø155 mm	Ø100 mm	Ø200 mm	Ø225 mm
Elliptical (W×H)	-	-	250 × 50 mm	300 × 70 mm
Flat (W×T)	-	-	300 × 10 mm	350 × 20 mm

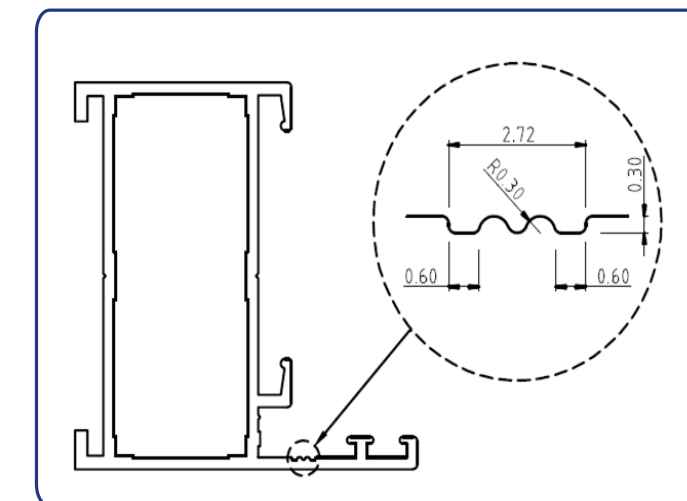

Serving Industries

Leveraging a broad portfolio and competitive edge to deliver excellence in construction, automotive, and renewables.

Building & Construction Segment



- ◆ Made-to-order aluminium extrusions for façades, curtain walls, and cladding system in different size and finishes.
- ◆ Our catalogue contains more than 18,000 sections that Bhoruka has developed by virtue of being in the industry for more than 44 years



- ◆ We hold the unique distinction of supplying high-quality aluminium extrusions to globally reputed to Door Window systems as follows:
- ◆ Airclos, AluK, Asahi, Dorma, IWIN, Schueco and others.

OEM / Industrial Segment



Diverse Portfolio

- › Solar Panels
- › Automotive
- › Electrical and Electronic Equipment's
- › Machine Members

Bhoruka's Competitive Edge

- › Under One Roof –EXT, PC/ANO, FAB
- › Compliance and Certifications
- › Total Cost of Ownership
- › Sustainability

Automotives

- › Roof Rails
- › Nudge Guards
- › EV Battery Enclosures

Scale Opportunity

- › Expand to other OEMs
- › Target Renewable Energy Sectors

Bhoruka 360

Leveraging on Technology - Bhoruka 360 - The Industry first CRM module for the customer.

The interface includes the following components:

- SO Status Page:** Features a search bar for 'Company Code', 'Order Date' filters (From: 01 Jul 2024, To: 26 Jul 2024), and a table with columns '#', 'PO No.', and 'PO Date'. A sample entry shows PO No. 'challan#338 & po 453' with a date of 26 Jul 2024.
- Summary Dashboard:** Displays key metrics: Open SO (11), Total MT Ordered (1684.93 MT from April 2019), and Invoiced Raised (67 This month).
- Dispatch Chart:** A bar chart titled 'SO & Dispatch Month wise (Current FY)' showing metrics in tonnes across months from April to August.
- Dispatch Status Page:** Includes a 'Load' button and a table with columns: PO No., PO Date, SO No., Doc No., Inv. No., and Inv. Date. A sample record shows PO No. 4501092732, PO Date 01 Apr 2024, SO No. 0032023580, Doc No. 0094439815, Inv. No. BE2400002225, and Inv. Date 26 Jul 2024.

- › Track shipments
 - › Make a request for factory visit
 - › Track all past transactions and invoices
 - › Check all contracts and agreements
 - › Access the product catalogue
 - › Escalate unresolved issue
- ◆ all on real-time basis

◆ **Our Customers Can**

- › Release PO to Bhoruka, Get a PI
- › Approve the PI online
- › Check SO status
- › Check production progress
- › Check deliveries and access financial ledgers

3D Printing

Industry's First Extruder to have 3D Printing Technology

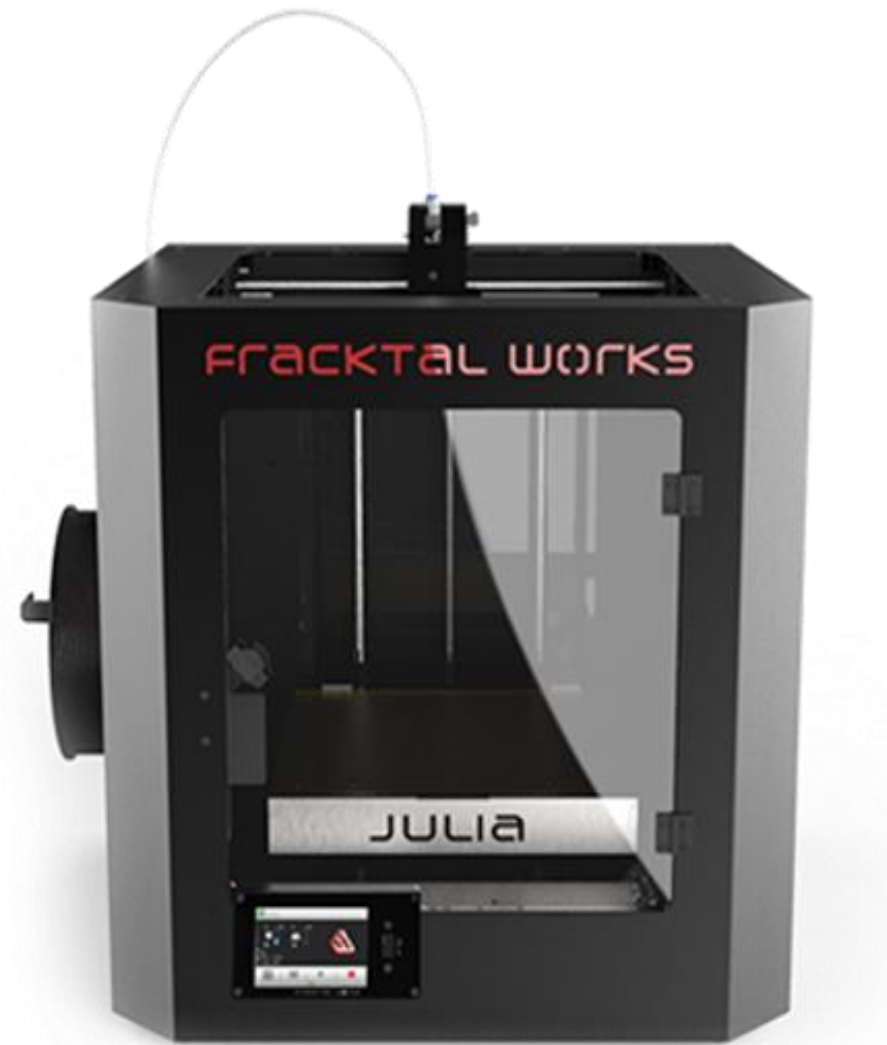

- › FFF printing technology with auto platform calibration.
- › Print up a 60-micron resolution with a 0.25mm nozzle.
- › Comes in various sizes. The machine has a build volume of 300mm x 300mm x 400mm

3D Printed Samples developed prior to Die Development



- › Customers can test the product for snap/slide fitment or gasket development prior to die manufacturing
- › Visualize and test the profile's form and fit quickly before committing to die manufacturing.

Eco-friendly Manufacturing

At Bhoruka Extrusions, sustainability isn't just a goal-it's a responsibility we live by every day with every product we supply is ROHS & REACH compliant, proving that safety and responsibility can go hand in hand

Here's how we're making a difference:



Our 16-acre manufacturing facility is home to **260+ trees**, reflecting our commitment to a greener and more sustainable environment



Our **Press-3 facility** is equipped with Roof-top-Solar which has the capacity to generate the Solar power of **418KWP**



Introduced **biodegradable poly cover packing** for aluminium profiles, made from renewable materials which is Fully decomposable, eco-safe alternative to HDPE

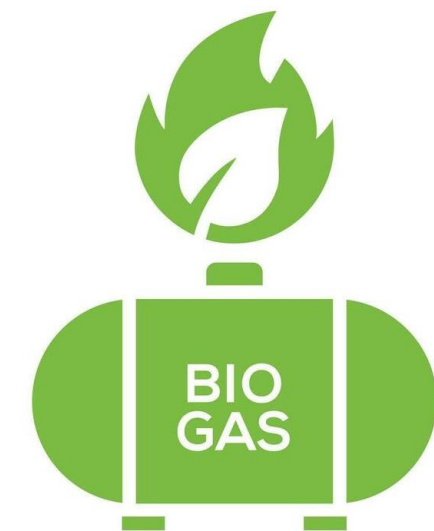

Implemented sustainable practices including **75% aluminium chip recovery**, **95% treated water reuse**, **20% packaging reduction**, **biogas** from canteen waste, **ETP sludge reduction**, and CNG fleet with solar energy.

Sustainability Actions

Bhoruka is advancing cleaner energy, reducing CO₂ emissions through innovative practices, and investing in energy-efficient technologies, aligned with YKK AP's goal of achieving zero environmental impact across the entire product lifecycle by 2050

Scope 1 & Scope 2 Emissions

3,405 tCO₂e
Scope 1

900 tCO₂e
Scope 2

We have achieved a 43% reduction in Scope 2 emissions over the past two years, bringing our energy-related footprint down from 1,567 tCO₂e in FY2023 to just 900 tCO₂e in FY2025 - a clear reflection of our transition to cleaner energy sources.

Scope 1 emissions have increased alongside our operational growth, rising from 2,923 tCO₂e in FY2023 to 3,405 tCO₂e in FY2025.

Energy Management

88.34%

Renewable Energy Share

+23% YoY

Increase in renewable energy usage

54%

PNG Usage Increase

In FY 2024-25, the Mysuru plant consumed 11,897 MWh of electricity, with 88.34% sourced from renewables (a 23% increase), improving energy intensity to 1.02 MWh per tonne despite an 18% rise in production, while a 54% increase in PNG usage reduced LPG and diesel consumption by 69% and 28%, respectively.

Water & Waste Management

9.25

Kg per tonne Waste Intensity Improved

32%

Of Total Water Consumption met Through recycled Water

In FY 2024-25, the Mysuru facility generated 108,047 kg of waste (96% hazardous) and strengthened circular water practices, with 32% of water recycled through its ETP and STP systems.

ENVIRONMENTAL PRODUCT DECLARATION



India's First Aluminium Extruder with Certified EPD

Bhoruka Extrusions is **India's first aluminium extruder** to publish an internationally verified Environmental Product Declaration (EPD), based on Life Cycle Assessment (LCA) as per ISO 14025 and EN 15804 standards, reinforcing our commitment to responsible and sustainable manufacturing

EPD Registration: EPD-IES-0028927
Version date: 18 March 2026
Validity date: 17 March 2031

1 Tonne

Declared Unit

FY2024-25

Data Period

17.4 kg CO₂ / kg

Carbon Footprint

4.4%

Post-Consumer Recycled Content

EPD International

Programme Operator

EPD India

Licensee

Certifications

Quality Compliance

Bhoruka Extrusions ensures strong quality compliance, holding ISO - QMS certification, BIS licenses and Work Approvals Certificate from Indian Register of Shipping for stringent quality standards

ISO 9001: 2015 for QMS from Bureau Veritas



BHORUKA EXTRUSIONS PVT. LTD.
BHORUKA
 A YKK AP COMPANY

NO. 1, KRS ROAD, METAGALLI, MYSURU – 570 016, KARNATAKA, INDIA.

Bureau Veritas Certification Holding SAS – UK Branch certifies that the Management System of the above organisation has been audited and found to be in accordance with the requirements of the Management System Standard detailed below.

Standard
ISO 9001:2015
 Scope of certification

MANUFACTURE OF MILL FINISH, ANODIZED AND POWDER COATED ALUMINIUM EXTRUSIONS IN STANDARD AND FUNCTIONAL SHAPES FOR STRUCTURAL / ARCHITECTURAL COMPONENTS, TRANSPORT, TEXTILE AND ELECTRICAL INDUSTRIES

Original cycle start date: **12 March 1995**
 Recertification cycle start date: **09 December 2024**
 Subject to the continued satisfactory operation of the organisation's Management System, this certificate is valid until: **12 December 2027**
 Certificate No. **IND.24.2447/QM/U** Version: 1 Issue date: **09 December 2024**

For certificate authenticity, click here <https://certcheck.ukas.com/>

ISO 9001 IN049168

UKAS MANAGEMENT SYSTEMS

0008

Certification body address: 5th Floor, 100 Lower Thames Street, London, EC3R 6DL, United Kingdom

Local office: Bureau Veritas (India) Private Limited (Certification Business), 72 Business Park, Marol Industrial Area, MIDC Cross Road, 1st, Andheri (East), Mumbai – 400 093, India

Further clarifications regarding the scope of this certificate and the applicability of the management system requirements may be obtained by consulting the organisation.
 To check this certificate validity please call + 91 22 6274 2000.

BIS License for Quality Compliance – IS 733



भारतीय मानक ब्यूरो
Bureau of Indian Standards
 The National Standards Body of India

For any other communication

Bengaluru Branch Office-
 Peenya Industrial Area, 1st
 Stage, Bangalore - Tumkur
 Road, Bangalore, BANGALORE
 RURAL, KARNATAKA, 560058

Address: Bengaluru Branch Office-
 Peenya Industrial Area, 1st
 Stage, Bangalore - Tumkur
 Road, Bangalore, BANGALORE
 RURAL, KARNATAKA, 560058

Phone: 08028394955
 Fax: 08028398841
 E-Mail: bnbo@bis.gov.in
 Web: www.bis.org.in,
 www.manakonline.in

Our Ref.:BNBO/CML 6200220480 Dated: 26-11-2024

Subject: Grant of BIS Certification Marks Licence No 6200220480 as per IS 733:1983.
M/S BHORUKA EXTRUSIONS PRIVATE LIMITED
 No-01, K.R.S. Road, Metagalli Industrial Area, Mysuru, MYSORE, MYSORE, KARNATAKA, INDIA 570016

Dear Madams(s)/Sir,
 With reference to your application, we are pleased to inform you that the Certification Marks Licence has been granted to you to use the Standard Mark in respect of the followings:
Wrought Aluminium and Aluminium Alloy Bars, Rods and Sections (for General Engineering Purposes)
 Product:-

Grade/Class/Type/Variety
Name of the product: Wrought Aluminium and Aluminium Alloy Bars Rods and Sections For General Engineering Purposes as per IS 733 for following scope 1 Type of section Regular Section Dimensions Sizes Width 11 mm to 260 mm Thickness 0.9 mm to 20 mm Condition Temper designations T6 Designation 63400 64430 65032 2 Type of section Rod Dimensions Sizes Diameter 5 mm to 120 mm Condition Temper designations: T4 Designation 63400 64430 65032 3 Type of section Rod Dimensions Sizes Diameter 5 mm to 120 mm Condition Temper designations T6 Designation 63400 64430 65032 4 Type of section Bar Dimensions Size Width 10 mm to 300 mm Thickness 2 mm to 20 mm Condition Temper designations T4 Designation 63400, 64430, 65032 5 Type of section Bar Dimensions Sizes Width 10 mm to 300 mm Thickness 2 mm to 20mm Condition Temper designations T6 Designation 63400 64430 65032 6 Type of section Regular Section Dimensions Sizes Width 11 mm to 260 mm Thickness 0.9 mm to 20 mm Condition Temper designations T4 Designation 63400 64430 65032 7 Type of section Irregular section Dimensions Sizes Width 15 mm to 250 mm Thickness 1.5 mm to 20 mm Condition Temper designations T4 Designation 63400 64430 65032 8 Type of section Irregular section Dimensions/Sizes Width 15 mm to 250 mm Thickness-1.5 mm to 20 mm Condition Temper designations T6 Designation 63400 64430 65032

1. The licence is granted on the explicit condition that you will mark entire/substantial production which conforms to the Indian Standards.

2. The number assigned to this licence is CML/ 6200220480 which has been made operative from 2024-11-13 and is valid upto 2025-11-12. The licence number should invariably be referred to in your future correspondence.

According to sub-regulation (1) &(3) of Paragraph 5 of scheme I of Schedule II under Bureau of Indian Standards (Conformity of Assessment) Regulation, 2018, the annual licence fee of Rs. 1000.00 and the marking fee for use of standard mark as per Annexure-I of Scheme I of BIS(Conformity assessment) Regulation 2018 is payable by you with

BIS License for Quality Compliance – IS 1285



भारतीय मानक ब्यूरो
Bureau of Indian Standards
 The National Standards Body of India

For any other communication

Bengaluru Branch Office-
 Peenya Industrial Area, 1st
 Stage, Bangalore - Tumkur
 Road, Bangalore, BANGALORE
 RURAL, KARNATAKA, 560058

Address: Bengaluru Branch Office-
 Peenya Industrial Area, 1st
 Stage, Bangalore - Tumkur
 Road, Bangalore, BANGALORE
 RURAL, KARNATAKA, 560058

Phone: 08028394955
 Fax: 08028398841
 E-Mail: bnbo@bis.gov.in
 Web: www.bis.org.in,
 www.manakonline.in

Our Ref.:BNBO/CML 6200220379 Dated: 26-11-2024

Subject: Grant of BIS Certification Marks Licence No 6200220379 as per IS 1285:2023.
M/S BHORUKA EXTRUSIONS PRIVATE LIMITED
 No-01, K.R.S. Road, Metagalli Industrial Area, Mysuru, MYSORE, MYSORE, KARNATAKA, INDIA 570016

Dear Madams(s)/Sir,
 With reference to your application, we are pleased to inform you that the Certification Marks Licence has been granted to you to use the Standard Mark in respect of the followings:
WROUGHT ALUMINIUM AND ALUMINIUM ALLOYS EXTRUDED ROUND TUBE AND HOLLOW SECTIONS FOR GENERAL ENGINEERING PURPOSES SPECIFICATION
 Product:-

Grade/Class/Type/Variety
Name of the product: Wrought Aluminium and Aluminium Alloys-Extruded Round Tube and Hollow Sections for General Engineering Purposes as per IS 1285 for following varieties 1 Type of section Round Tube Dimensions Sizes Outside Diameter 8 mm to 200 mm Wall Thickness 1.3 mm to 6 mm Condition Temper designations T4 Designation 63400 64423 64430 65032 2 Type of section Round Tube Dimensions Sizes Outside Diameter 8 mm to 200 mm Wall Thickness 1.3 mm to 6 mm Condition Temper designations T6 Designation 63400 64423 64430 65032 3 Type of section Hollow Sections Dimensions Sizes Outside Width 10 mm to 275 mm Outside Height 10 mm to 70 mm Wall Thickness 1.5 mm to 10 mm Condition Temper designations T4 Designation 63400 64423 64430 65032 4 Type of section Hollow Sections Dimensions Sizes Outside Width 10 mm to 275 mm Outside Height 10 mm to 70 mm Wall Thickness 1.5 mm to 10 mm Condition Temper designations T6 Designation 63400 64423 64430 65032

1. The licence is granted on the explicit condition that you will mark entire/substantial production which conforms to the Indian Standards.

2. The number assigned to this licence is CML/ 6200220379 which has been made operative from 2024-11-13 and is valid upto 2025-11-12. The licence number should invariably be referred to in your future correspondence.

According to sub-regulation (1) &(3) of Paragraph 5 of scheme I of Schedule II under Bureau of Indian Standards (Conformity of Assessment) Regulation, 2018, the annual licence fee of Rs. 1000.00 and the marking fee for use of standard mark as per Annexure-I of Scheme I of BIS(Conformity assessment) Regulation 2018 is payable by you with effect from 2024-11-13 for the period of validity of the licence licence in advance.

Indian Register of Shipping Works Approval Certificate

PROVISIONAL



Indian Register of Shipping

Certificate No.: 2025WAC016

WORKS APPROVAL CERTIFICATE

This is to certify that based on the existing manufacturing facilities and satisfactory assessment of manufacturing and quality control procedures by our Surveyors, the name of

BHORUKA EXTRUSIONS PVT LTD,
 No. 1 K.R.S. Road, Metagalli, Mysore, Karnataka - 570016

is included in the list of approved works in accordance with the relevant requirements of rule(s)/standard(s)/code described below.

WORKS TYPE : MANUFACTURER OF ALUMINIUM SECTIONS
PRODUCT TYPE : MANUFACTURER OF SECTIONS OF WROUGHT ALUMINIUM ALLOYS
APPLICABLE RULE(S)/STANDARD(S)/CODE: Part 2 Chapter 9 of IRS Rules and Regulations for the Construction and Classification of Steel Ships, July 2024
SCHEDULE OF APPROVAL : SEE ANNEXURE I

This Certificate is Valid until : 10/09/2026

PLACE OF ISSUE: MUMBAI
 DATE OF ISSUE: 11/09/2025
 LOCAL SURVEY OFFICE: CHENNAI

FOR INDIAN REGISTER OF SHIPPING
 Digitally Signed By: Uday Amrutkar
 Place: Mumbai
 Date: 11/09/2025 (dd/mm/yyyy)

Principal Surveyor

This Certificate is issued upon the following terms and conditions as laid down in the Society's Regulations:-
 Whilst Indian Register of Shipping, a Classification Society, along with its subsidiaries and associates (hereinafter referred to as the Society) and its Board/Committee use their best endeavours to ensure that the functions of the Society are properly carried out, in providing services, information or advice neither the Society nor any of its servants or agents warrants the accuracy of any information or advice supplied. Except as set out herein neither the Society nor any of its servants or agents (on behalf of each of whom the Society has agreed this clause) shall be liable for any loss, damage or expense whatsoever sustained by any person due to any act or omission or error of whatsoever nature and however caused of the Society, its servants or agents or due to any inaccuracy of whatsoever nature and however caused in any information or advice given in any way whatsoever by or on behalf of the Society, even if held to amount to a breach of warranty. Nevertheless, if any person uses services of the Society, or relies on any information or advice given by or on behalf of the Society and suffers loss, damage or expense thereby which is proved to have been due to any negligent act, omission or error of the Society, its servants or agents or any negligent inaccuracy in information or advice given by or on behalf of the Society then the Society will pay compensation to such person for his proved loss up to but not exceeding the amount of the fee charged by the Society for that particular service, information or advice.
 Any notice of claim for loss, damage or expense, as referred to above, shall be made in writing to the Society's Head Office within six months of the date when the service, information or advice was first provided, failing which all the rights to any such claim shall be forfeited and the Society shall be relieved and discharged from all liabilities.

Form No.: IRS_WAC_QC (Rev.2)
 TID: IRS/2025/2025WAC016/22766

Page 1 of 2

Certifications

Environmental sustainability and compliance

Bhoruka Extrusions is committed to environmental sustainability by aligning its practices with IGBC and GRIHA green building standards, along with ISO Environmental Management System (EMS) certification

GRIHA Certified for Aluminium Extrusions & IWIN Doors & Windows



RP16GPC00255

GRIHA Council
This is to certify that the products of
“Bhoruka Extrusions Private Limited”
IWIN Range of Aluminium Doors and Windows
(under Typology: Doors & Windows: panels and frames)
have been included in the GRIHA Product Catalogue under the following categories:
GRIHA V.2015 criterion: 21 & SVAGRIHA criterion: 12
and
Aluminium extrusions
(Under Typology: Innovation products)
has been included in the GRIHA Product Catalogue under the following categories:
GRIHA V.2015 criterion: 31 & SVAGRIHA criterion: 14
The products can be used in GRIHA & SVAGRIHA registered projects to meet the GRIHA & SVAGRIHA norms, respectively. This is valid only for the products which have been mentioned above.
The certificate for the above-mentioned products is valid from
22nd June 2026 to 21st June 2028

Sanjay Seth
Vice President & Chief Executive Officer

Note:
1. Before selecting the above specified products, it is recommended to revalidate that the project is meeting the GRIHA's mandatory compliances.
2. This evaluation has been done based on the documentation - in the form of 3rd party test results and/or declarations - submitted by the manufacturer to GRIHA Council.
3. The enlisted product(s) only qualify for the criterion mentioned in the certificate.

GRIHA Council is a joint initiative of Ministry of New and Renewable Energy, Government of India and The Energy and Resources Institute (TERI) to implement GRIHA (Green Rating for Integrated Habitat Assessment), India's National Rating System for Sustainable Habitats.
www.grihaindia.org

IGBC Certified for Aluminium Extrusions & IWIN Doors & Windows



Confederation of Indian Industry

Membership Certificate
This is to certify that
Bhoruka Extrusions Pvt Ltd
is an Annual Member of Indian Green Building Council (IGBC)
Bearing Membership No **IGBCM170151**
This certificate shall be valid up to December 2026

K S Venkatagiri
Executive Director
CII - IGBC

B Thiagarajan
Chairman
Indian Green Building Council

C Shekar Reddy
Vice Chairman
Indian Green Building Council

Indian Green Building Council
CII - Sohrabji Godrej Green Business Centre, Survey No. 64, Near Hitech City, R R Dist, Hyderabad - 500 084
T: +91 40 4418 5132 / 33 F: +91 40 4418 5189 E: igbc@cii.in W: igbc.in

ISO 14001: 2015 for Environmental Management System from Bureau Veritas



BHORUKA EXTRUSIONS PVT. LTD.
BHORUKA
A YKK AP COMPANY
No. 1, KRS Road, Metagalli, Mysore - 570 016, Karnataka, India.

Bureau Veritas Certification Holding SAS - UK Branch certifies that the Management System of the above organisation has been audited and found to be in accordance with the requirements of the Management System Standard detailed below.

Standard
ISO 14001:2015
Scope of certification

MANUFACTURE OF MILL FINISH, ANODIZED AND POWDER COATED ALUMINIUM EXTRUSIONS IN STANDARD AND FUNCTIONAL SHAPES FOR STRUCTURAL / ARCHITECTURAL COMPONENTS, TRANSPORT, TEXTILE AND ELECTRICAL INDUSTRIES.

Original cycle start date: 23 December 2025
Certification cycle start date: 23 December 2025
Subject to the continued satisfactory operation of the organisation's Management System, this certificate is valid until: 22 December 2028
Certificate No. IND.25.2483/EM/U Version: 1 Issue date: 23 December 2025

For certificate authenticity, click here
<https://certcheck.ukas.com/>

Signed on behalf of BVCH SAS UK Branch
Dr. J N MANIAN
Director - CERTIFICATION, South Asia
Commodities, Industry & Facilities Division

Certification body address: 5th Floor, 100 Lower Thames Street, London, EC3R 6DL, United Kingdom.
Local office: Bureau Veritas (India) Private Limited (Certification Business)
72 Business Park, Marol Industrial Area, MIDC Cross Road "C",
Andheri (East), Mumbai - 400 053, India.

Further clarifications regarding the scope of this certificate and the applicability of the management system requirements may be obtained by consulting the organisation.
To check this certificate validity please call + 91 22 6274 2000.

Certifications

REACH and RoHS COMPLIANT

Bhoruka Extrusions is committed to environmental sustainability by aligning its practices with IGBC and GRIHA green building standards, and ensuring product compliance with RoHS and REACH environmental regulations

REACH Compliant for Mill Finish & Anodized Finishes from TUV India

TUVINDIA

Test Report

Report No : TUV(I)/NL-145/25-26/NL-0525000151 PI
 Date : 14 May 2025
 Name and address of customer : Bhoruka Extrusions Pvt Ltd
 #1,KRS Road, Metagalli,
 Mysore
 Pin Code: 570016
 Reg No. : NL-145/25-26
 CA No. : NL-0525000151
 Name of the sample : Recycle more than 75% aluminium content-BSM -(Silver)Anodising
 Batch No. : Grade :- 6063-T6 Alloy - Color :- BSM-(SILVER)
 Discipline : Chemical
 Product Category : Metal
 Date of sample receipt : 06 May 2025
 Date(s) of analysis : 08 May 2025 - 14 May 2025
 Objectives of Examination : As requested by client, SVHC screening is performed according to:
 (i) Two hundred and Forty-Seven (247) substances in the Candidate List of Substances of Very High Concern (SVHC) for authorization published by European Chemicals Agency (ECHA) Regulation (EC) No 1907/2006 concerning the REACH.
 Article 33 of Regulation (EC) No 1907/2006 requires supplier of an article containing a substance meeting the criteria in Article 57 and identified in accordance with Article 59(1) in a concentration above 0.1% weight by weight (w/w) shall provide the recipient of the article with sufficient information.
 REACH Requirement : identified in accordance with Article 59(1) in a concentration above 0.1% weight by weight (w/w) shall provide the recipient of the article with sufficient information.

Results Summary:
 According to the specified scope and evaluation screening, the results of SVHC are Below 0.1 % (w/w) in the submitted sample. PASS

Authorized by
 Rabindra Samal,
 Assistant Manager- Operation - ACMT Lab

TUV India Private Limited
 Registered & Head Office: 801, Raheja Plaza-1, L.B.S. Marg, Chhatkopar (W), Mumbai - 400 086 • CIN: U74140MH1989PTC052930
 Laboratory Address: 1st Floor, A72, Block A, Sector 64, Noida, Uttar Pradesh - 201305
 Phone No 0120-4634210 • Toll free: 1800-209-0902 • E-mail: acmtlab@tuv-nord.com • URL: www.tuv-nord.com/in

RoHS Compliant for Mill Finish & Anodized Finished from TUV India

TUVINDIA



Test Report

Report No : TUV(I)/NL-145/25-26/NL-0525000150 PI
 Date : 14 May 2025
 ULR : TC1382225000002794F
 Name and address of customer : Bhoruka Extrusions Pvt Ltd
 #1,KRS Road, Metagalli,
 Mysore
 Pin Code: 570016
 Reg No. : NL-145/25-26
 CA No. : NL-0525000150
 Name of the sample : Recycle more than 75% aluminium content-Black Anodising
 Batch No./ Code no. : Grade :- 6063-T6 Alloy
 Color :- BLACK
 Discipline : Chemical
 Product Category : Metal
 Date of sample receipt : 06 May 2025
 Date(s) of analysis : 08 May 2025 - 14 May 2025
 Sample drawn by : Customer
 Objectives of Examination : As per RoHS Directive (EU) 2015/863 amending Annex II to Directive 2011/65/EU
 Test Requirement : RoHS 10E

Results Summary:
 Based on the performed tests on submitted sample(s), the results of Cadmium, Lead, Mercury, Hexavalent chromium, Polybrominated biphenyls (PBBs), Polybrominated diphenyl ethers (PBDEs) and Phthalates such as Bis(2-ethylhexyl) phthalate (DEHP), Butyl benzyl phthalate (BBP), Dibutyl phthalate (DBP) and Diisobutyl phthalate (DIBP) Comply with the limits as set by RoHS Directive (EU) 2015/863 amending Annex II to Directive 2011/65/EU

Authorized by
 Rabindra Samal,
 Assistant Manager- Operation - ACMT Lab



TUV India Private Limited
 Registered & Head Office: 801, Raheja Plaza-1, L.B.S. Marg, Chhatkopar (W), Mumbai - 400 086 • CIN: U74140MH1989PTC052930
 Laboratory Address: 1st Floor, A72, Block A, Sector 64, Noida, Uttar Pradesh - 201305
 Phone No 0120-4634210 • Toll free: 1800-209-0902 • E-mail: acmtlab@tuv-nord.com • URL: www.tuv-nord.com/in

RoHS & REACH Compliant for Powder Coating Finish from TUV India

TUVINDIA



Test Report

Report No : TUV(I)/NL-220/25-26/NL-0525000620
 Date : 31 May 2025
 ULR : TC1382225000003043F
 Name and address of customer : Bhoruka Extrusions Pvt Ltd
 #1,KRS Road, Metagalli,
 Mysore
 Pin Code: 570016
 Reg No. : NL-220/25-26
 CA No. : NL-0525000620
 Name of the sample : Recycle more than 75% aluminium content-Powder Coating sample
 Batch No. : Grade :- 6063-T6 Alloy
 Colour :- Anodic Bronze colour Powder (SW28BN)
 Discipline : Chemical
 Product Category : Polymer
 Date of sample receipt : 26 May 2025
 Date(s) of analysis : 29 May 2025 - 31 May 2025
 Sample drawn by : Customer
 Objectives of Examination : As per RoHS Directive (EU) 2015/863 amending Annex II to Directive 2011/65/EU
 Test Requirement : RoHS 10E

Results Summary:
 Based on the performed tests on submitted sample(s), the results of Cadmium, Lead, Mercury, Hexavalent chromium, Polybrominated biphenyls (PBBs), Polybrominated diphenyl ethers (PBDEs) and Phthalates such as Bis(2-ethylhexyl) phthalate (DEHP), Butyl benzyl phthalate (BBP), Dibutyl phthalate (DBP) and Diisobutyl phthalate (DIBP) Comply with the limits as set by RoHS Directive (EU) 2015/863 amending Annex II to Directive 2011/65/EU

Authorized by
 Rabindra Samal,
 Assistant Manager- Operation - ACMT Lab



TUV India Private Limited
 Registered & Head Office: 801, Raheja Plaza-1, L.B.S. Marg, Chhatkopar (W), Mumbai - 400 086 • CIN: U74140MH1989PTC052930
 Laboratory Address: 1st Floor, A72, Block A, Sector 64, Noida, Uttar Pradesh - 201305
 Phone No 0120-4634210 • Toll free: 1800-209-0902 • E-mail: acmtlab@tuv-nord.com • URL: www.tuv-nord.com/in

Certifications

Akzonobel - Approved Applicator

Bhoruka Extrusions is an approved applicator for AkzoNobel's Interpon D series -D1000, D2000, and D3000- offering warranty periods of 15, 25, and 30 years respectively.

Interpon D Approved Applicator D1000 -AAMA 2603



Interpon POWDER COATINGS **AkzoNobel**

Interpon D Approved Applicator

Interpon D1000 Series

Bhoruka Extrusions Pvt Ltd
#01, KRS Road, Metagalli, Mysore-570016 India

Has fulfilled AkzoNobel's tests and inspection regarding the pre-treatment, the application, the quality management standards, the procedures and Complies with the requirements of the Architectural Range Approved Applicator schedule.

This certificate is effective from
4th March 2025 to 4th March 2027

Approved for Aluminum Alloys: AA6063
Approved for Pre-treatment Type: Chromatizing

Digitally signed by P.V.R.NarasimhaRao
DN: cn=P.V.R.NarasimhaRao
Date: 2025.03.11 08:05:48 +05'30'

P.V.R.Narasimha Rao
Sales Manager, Powder Coatings, India

Date: 10th March 2025
Certification Number: IND 254-25

Akzo Nobel India Limited, Plot No. 62P, 62A, 62B, 43E, Hoskote Industrial Area, Bangalore - 562114, India

Interpon D Approved Applicator D2000 -AAMA 2604



Interpon POWDER COATINGS **AkzoNobel**

Interpon D Approved Applicator

Interpon D2000 Series

Bhoruka Extrusions Pvt Ltd
#01, KRS Road, Metagalli, Mysore-570016 India

Has fulfilled AkzoNobel's tests and inspection regarding the pre-treatment, the application, the quality management standards, the procedures and Complies with the requirements of the Architectural Range Approved Applicator schedule.

This certificate is effective from
5th March 2025 to 5th March 2027

Approved for Aluminum Alloys: AA6063
Approved for Pre-treatment Type: Chromatizing

Digitally signed by P.V.R.NarasimhaRao
DN: cn=P.V.R.NarasimhaRao
Date: 2025.03.11 08:05:07 +05'30'

P.V.R.Narasimha Rao
Sales Manager, Powder Coatings, India

Date: 10th March 2025
Certification Number: IND 255-25

Akzo Nobel India Limited, Plot No. 62P, 62A, 62B, 43E, Hoskote Industrial Area, Bangalore - 562114, India

Interpon D Approved Applicator D3000 -AAMA 2605



Interpon POWDER COATINGS **AkzoNobel**

Interpon D Approved Applicator

Interpon D3000 Series

Bhoruka Extrusions Pvt Ltd
#01, KRS Road, Metagalli, Mysore-570016 India

Has fulfilled AkzoNobel's tests and inspection regarding the pre-treatment, the application, the quality management standards, the procedures and Complies with the requirements of the Architectural Range Approved Applicator schedule.

This certificate is effective from
22nd May 2025 to 22nd May 2027

Approved for Aluminum Alloys: AA6063
Approved for Pre-treatment Type: Chromatizing

Digitally signed by P.V.R.NarasimhaRao
DN: cn=P.V.R.NarasimhaRao
Date: 2025.05.29 11:23:47 +05'30'

P.V.R.Narasimha Rao
Sales Manager, Powder Coatings, India

Date: 26th May 2025
Certification Number: IND 273-25

Akzo Nobel India Limited, Plot No. 62P, 62A, 62B, 43E, Hoskote Industrial Area, Bangalore - 562114, India

Certifications

Jotun - Approved Applicator

Bhoruka Extrusions is an approved applicator for Jotun's Façade, Super Durable Series & Durasol series - offering warranty periods of 15, 25, and 30 years respectively.

Jotun's Façade Series



Certificate of Approval

Bhoruka Extrusions Pvt. Ltd.
No. 1 KRS Road, Metagalli, Mysore - 570016

is certified as an Approved Applicator to coat

Jotun Façade Series

a product from Jotun Powder Coatings

This company fulfils the requirements set by Jotun Powder Coatings for pre-treatment and application of powder coatings. These include having the necessary equipment, process controls and technical knowledge to comply with Jotun Powder Coatings standards.

M Periza
Authorized Signatory
Jotun India Pvt. Ltd.

Date: 1st January 2025
(Certificate valid for one year from above date)

Jotun's Super Durable Series



Certificate of Approval

Bhoruka Extrusions Pvt. Ltd.
No. 1 KRS Road, Metagalli, Mysore - 570016

is certified as an Approved Applicator to coat

Jotun Super Durable Series

a product from Jotun Powder Coatings

This company fulfils the requirements set by Jotun Powder Coatings for pre-treatment and application of powder coatings. These include having the necessary equipment, process controls and technical knowledge to comply with Jotun Powder Coatings standards.

M Periza
Authorized Signatory
Jotun India Pvt. Ltd.

Date: 1st January 2025
(Certificate valid for one year from above date)

Jotun's Durasol Series



Certificate of Approval

Bhoruka Extrusions Pvt. Ltd.
No. 1 KRS Road, Metagalli, Mysore - 570016

is certified as an Approved Applicator to coat

Jotun Durasol Series

a product from Jotun Powder Coatings

This company fulfils the requirements set by Jotun Powder Coatings for pre-treatment and application of powder coatings. These include having the necessary equipment, process controls and technical knowledge to comply with Jotun Powder Coatings standards.

M Periza
Authorized Signatory
Jotun India Pvt. Ltd.

Date: 29th May 2025
(Certificate valid for one year from above date)



IWIN-S Aluminium Doors and Windows is a home-creation B2B brand designed by **YKK AP** with **Japanese Precision**. These are system windows tested **for air, water, and sound** performance, suitable for both residential and commercial projects.

- ◆ Profiles are manufactured and coated In-house at Bhoruka Extrusions
- ◆ Hardware's / Parts and Accessories are manufactured In-house at YKK AP
- ◆ Global Assurance, Japanese Excellence & Comprehensive In-house Capabilities

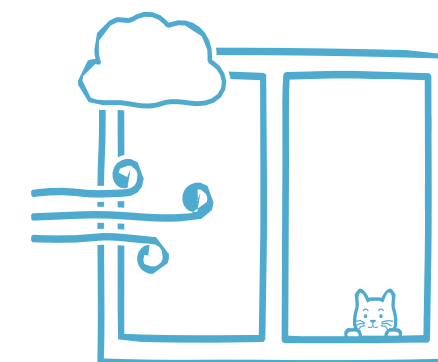

Structural
Wind load
2.5Kpa



Water
Tightness
300/350/600 Pa



Air
Infiltration
1.2m³/h·m²



Sound
Insulation
-30dB(Grade 2)



IWIN-E

Aluminum Windows & Doors

IWIN-E is our **new fenestration series** combining economic appeal and functionality. Designed for spaces with indirect environmental exposure

- ◆ Profiles are manufactured and coated In-house at Bhoruka Extrusions
- ◆ Hardware's / Parts and Accessories are manufactured In-house at YKK AP
- ◆ Global Assurance, Japanese Excellence & Comprehensive In-house Capabilities

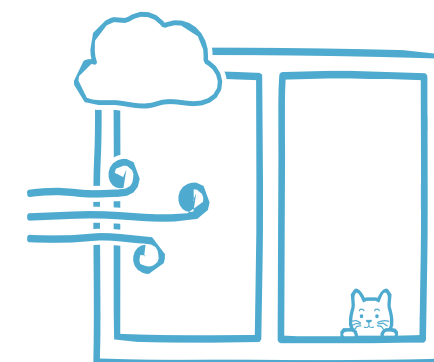

Structural
Wind load
1.2Kpa



Water
Tightness
150 Pa



Air
Infiltration
1.2m³/h·m²



Sound
Insulation
-30dB(Grade 2)

HO & Branch Details

Bhoruka Extrusions Pvt Ltd
No 1, KRS Road, Metagalli Industrial
Area, Metagalli, Mysore-570016

◆ Head-office

Mysore, Karnataka

Mr Pavan Kumar B S

pavan_kumar@bhorukaextrusions.com

+91-9148724427

◆ Bangalore Branch Office

Mr Vicky Appaiah

vicky_cs@bhorukaextrusions.com

+91-9731110088



◆ Chennai Branch Office

Mr Santhosh N

santhosh_n@bhorukaextrusions.com

+91-9840727164

◆ Delhi Branch Office

Mr Ashok Pareek

ashokkumar_pareek@bhorukaextrusions.com

+91-9844615202

◆ Hyderabad Branch Office

Mr Barath

barath_s@bhorukaextrusions.com

+91-9940021669

◆ Mumbai Branch Office

Mr Sudipta Raj Roy

sudiptaraj_roy@bhorukaextrusions.com

+91-7738012404

◆ Pune Branch Office

Mr Rajesh Varshney

rajesh_varshney@bhorukaextrusions.com

+91-9980713838



Extruding Excellence !